

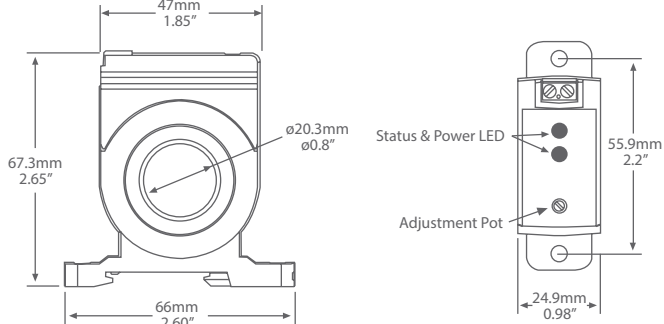

CURRENT SWITCH



cUL US LISTED



CS-610-200

PRODUCT DESCRIPTION

The CS Series current switch monitors line current for electrical loads such as pumps, conveyors, lighting, heaters or fans and closes the output contacts when the trip point is exceeded. The CS-610-200 has a trip point that is adjustable between 1 to 200 Amps by rotating the adjustment pot. A LED illuminates when trip point setting is reached.

The sensor requires no external power as it is totally powered by induction from the AC line being monitored. The switch output is normally open and when the input current exceeds the trip setpoint the switch closes to provide an on/off digital signal to the controller.

SPECIFICATIONS

CURRENT SETPOINT	Adjustable - 1 to 200 Amps
MAXIMUM INPUT CURRENT	200 Amps continuous
SENSOR POWER	Self-powered
OUTPUT TYPE	Solid-state mosfet
OUTPUT SWITCH ACTION	Normally open
INDICATION	Illuminated power status
OUTPUT SWITCH RATINGS	30 Vac/dc, 500 mA maximum
VON @ 24 VDC AT 500 mA	<50 mV
FREQUENCY	50/60 Hz
RESPONSE TIME	200 mS typical
INSULATION CLASS	600 Vac, insulated conductors
OPERATING TEMPERATURE	-15 to 50°C (5 to 122°F)
OPERATING HUMIDITY	5 to 90 %RH non-condensing
WIRING CONNECTIONS	Screw terminal block (14 to 22 AWG)
DIMENSIONS	67mm W x 68mm H x 24.1mm D (2.65" x 2.7" x 0.95")
SENSOR APERTURE	20.3mm (0.8")
ENCLOSURE MATERIAL	ABS/PC, UL94-V0
AGENCY APPROVALS	cULus listed

TYPICAL INSTALLATION

For complete installation and wiring details, please refer to the product installation instructions.

The CS-610-200 provides mounting tabs to secure the device inside a motor control panel using (2) #10 screws.

The sensor has a 2 wire connection to the Building Automation System.

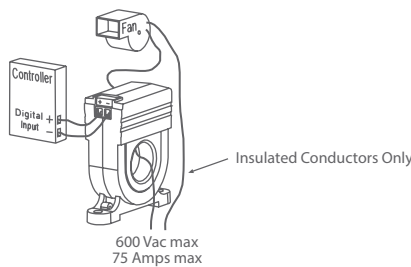

ORDERING

CURRENT SWITCH, ADJUSTABLE

CS-610-200

NOTE: Greystone Energy Systems, Inc. reserves the right to make design modifications without prior notice.

PART NUMBER

CS-610-200