

CAS04

4 channel monitoring with bar graphs



Instruction manual

To ensure that our product always meets the promised quality in all conditions, we advise you to read this manual carefully and to strictly follow the recommendations given.

Content

1. Introduction:.....	3
2. Technical descriptions CAS04 – 4 channel monitoring:.....	4
3. Warnings and safety instructions.	4
4. Overview:.....	5
5. Electrical connection.....	6
6. Input Type Selection:.....	6
7. Lamp on alarm:	6
8. Configuring the channel:	7
9. Technical data:	7

1. Introduction:

The CAS04 is a 4-channel monitoring system with a bar graphs display, that takes standard current and voltage signals as input.

And it has the option to monitor an active or passive current sensor.

The top and bottom level for each channel, and the alarm level for each channel can be configured independently.

There are 2 alarm outputs that work as a common alarm, i.e. an alarm that activates if the alarm level is exceeded on any of the 4 channels.

- Alarm 1:** Is a continuous alarm, which can be used for a flashing light alarm, for example.
A continuous alarm means that the alarm is active as long as the alarm limits are being exceeded.
- Alarm 2:** Is an alarm that can deactivated via the touch button on the front of the box. It is typically used for an external acoustic alarm.

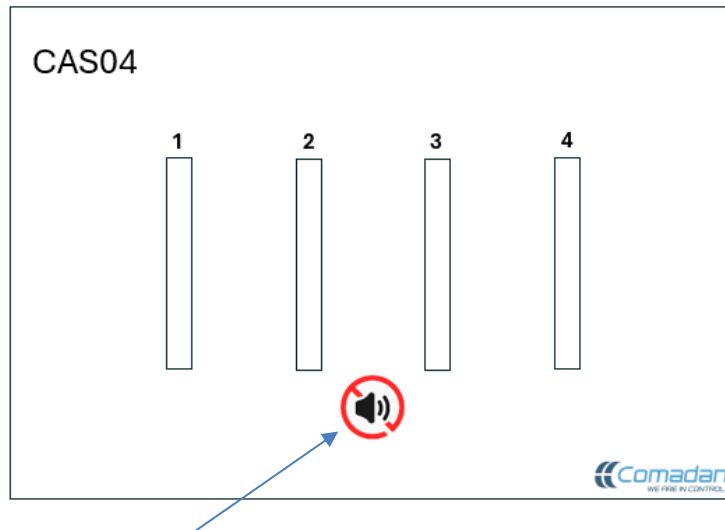

Alarm 2 – disable it by pressing the button on the front.

Both alarm outputs contains:

- Single pole changeover relay 230VAC – max 6 amps. - Output: 24VDC – max 100 mA.

2. Technical descriptions CAS04 – 4 channel monitoring:

The central alarm is built into an IP65 plastic box with cable grommet at the bottom of the box and a 2m mains supply cable.

4 channels that can run independently, 16 display segments per channel.

Each channel can be configured for 0-10 volts or 4-20 mA input.

4 channel monitoring is designed for installation in a normal environment – not ATEX.

Configuration and setting the levels is done via dip switches and push buttons on the PCB.

3. Warnings and safety instructions.



CAS04 - 4 channel monitoring must not be installed in potentially explosive atmospheres



IP65 enclosure protects against water ingress – but cleaning with a direct jet of a high-pressure cleaner should be avoided.



Electrical installations must be carried out by professionals in accordance with the Installation Order DS/EN 60364

All units must be grounded.



The units must not be exposed to harmful overvoltages.



The system is designed as an auxiliary tool and does not exempt personnel from their duty to supervise operation. The system and the system supplier cannot under any circumstances be held liable for operational losses or the like.

4. Overview:

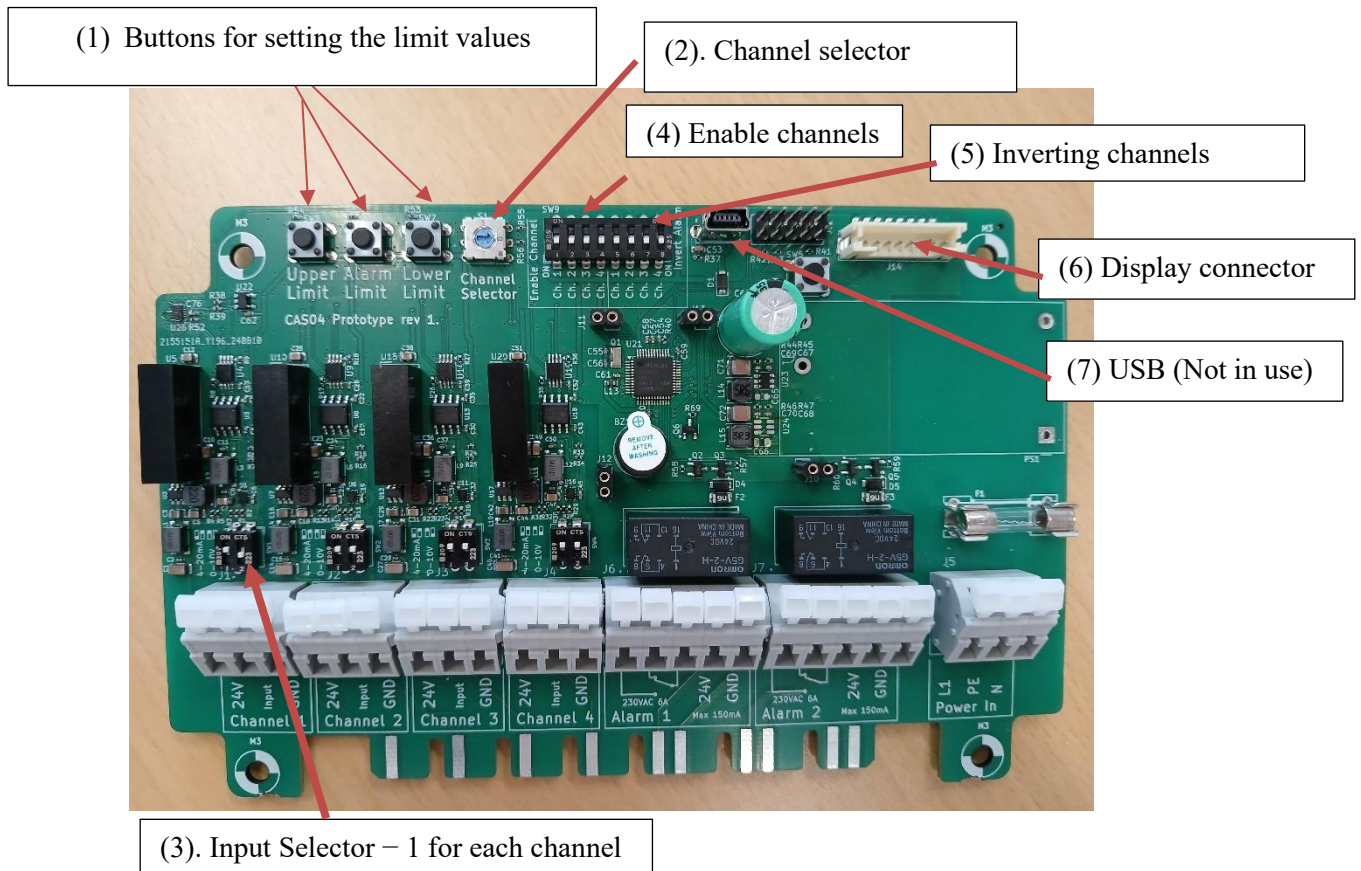

Explanation:

- (1) **Buttons for setting the limit value for the selected channel (2):**
 - Upper limit:** Sets the upper limit (i.e. the value that corresponds to full scale on the display).
 - Lower limit:** Sets the lower limit (i.e. the value that corresponds to zero on the display).
 - Alarm limit:** Sets the alarm level (where the alarm activates and the bar changes to red).
- (2) **Channel selector:** You turn the switch until it is on the channel you want to set.
- (3) **Input selector:** Here you switch between 0-10V and 4-20mA signal. (see Fig 1)
- (4) **Activation channel:** Here you can turn the individual channels on and off. (a channel off shows nothing in the display).
- (5) **Inversion of the channel:** Here you switch between whether the alarm pulls when the alarm limit is above or below the measured value.
 - At ON, the alarm threshold is at the bottom of the scale, which indicates alarm when pressure decreases.
- (6) **Display connector:** Here connects the cable for the display.
- (7) **USB.** Not in use. For internal testing and quality control.

5. Electrical connection



Here you will find the 4 sensor channels input.

There are 3 terminals per channel:

1. **24V:** is as the name suggests 24V sensor supply.
2. **Input:** This is where the signal from the sensor is connected.
3. **GND:** Ground in relation to **24V** and **Input**.

All the channels are galvanically isolated from each other and the rest of the system.

Alarms:

There are 5 connections per alarm: 3 for a changeover relay and 2 for a 24V output which is turned on when the alarm is activated. The 24V is not galvanically isolated from the alarm.

Supply:

There are 3 connections for the supply of the PCB. **L** for phase, **N** for neutral, and **PE** for ground.

6. Input Type Selection:

The CAS04 can monitor 0-10V or 4-20mA active or passive signal.

- For 0-10V, set the dip switches (3) to the 0-10V position (see fig. 1) and minus to the GND terminal and signal to the Input terminal.
- For 4-20mA active sensor, set the dip switches (3) to position 4-20mA (see fig 1) and minus to the GND terminal and signal to the Input terminal.
- For 4-20mA passive sensor, set the dip switches (3) to position 4-20mA (see fig 1) and minus to the Input terminal and plus to the 24V terminal.

7. Lamp on alarm:

If desired, a lamp can be switched on by the relay outputs as follows:

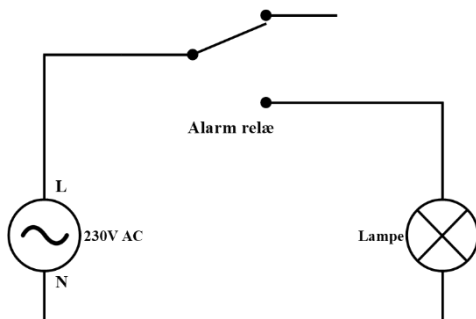

8. Configuring the channel:

1. Lid is unscrewed from the box.
2. Select whether the channel should be enabled on Enable channels (4).
3. If the channel is enabled, continue downwards with step 4.
4. Select whether the channel is inverted or not (5).
5. On the input selector (3), select 0-10V / 4-20mA.
6. Select the channel on the channel selector (2).
7. Top, bottom and alarm levels are set as follows:
 - a. Induce the desired signal level, either with a sensor or a signal calibrator instrument (e.g. MS4202).
 - b. Press the appropriate (top/bottom/alarm) button.
 - c. The display segments for the channel flashes once. The configuration is now saved.
8. Repeat for the other channels from step 2.
9. Put the lid back on the box again.

Select 0-10V/4-20mA:

The input switch is set as follows:

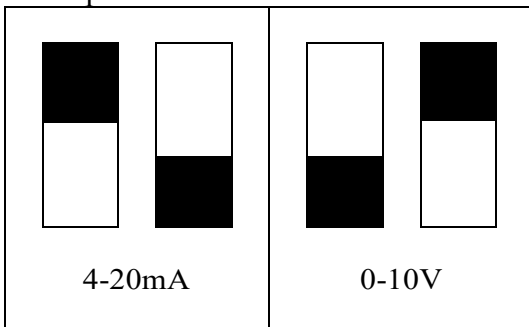

Fig 1.

9. Technical data:

Dimensions (H x L x D): 120 x 170 x 55 mm
 Protection class IP65

General electrical data

Fuse 500mA 230V slow-blow.
 Supply Voltage: 230 VAC \pm 10%
 Electricity Consumption: 15 VA
 Alarm Contacts: 240VAC, 6A

Electrical Data for Inputs

Configuration for Analog Inputs -
 Sensor Supply: 24 VDC (24 mA Max.)
 Measurement signal: 4-20 mA:
 Internal resistance: 12 ohms.
 Voltage drop across input at 20mA: \sim 0.24VDC.
 Measurement signal: 0-10 VDC:
 Internal resistance: 100k ohms.

Other conditions:

Conditions of use Application temperature: 0 to 40°C
 Humidity (relative maximum): 95% at 40°C+